

PBLS22GEL Series

Planetary Gearbox BLDC Motor

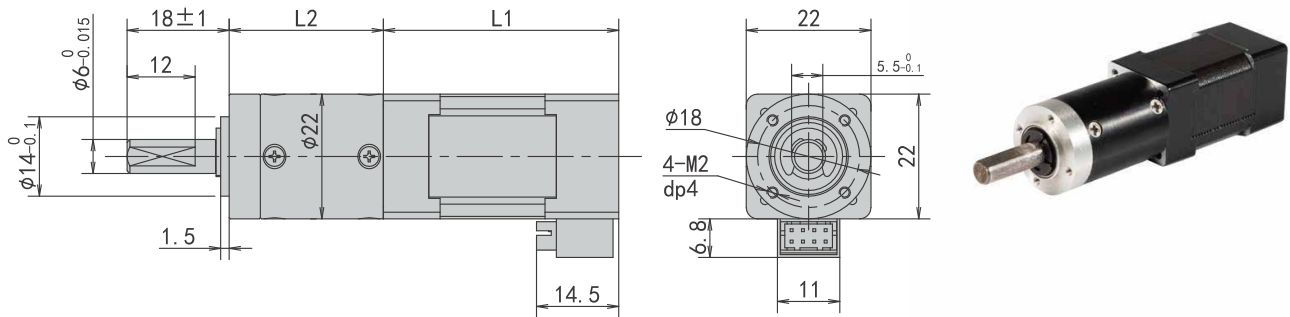

Motor Specifications

Motor Model	Unit	PBLS22GEL240440	PBLS22GEL240840	PBLS22GEL241840
Number of Phase		3		
Number of Poles		8		
Rated Voltage	VDC	24		
Rated Speed	Rpm	4000		
Rated Torque	N.m	0.01	0.02	0.03
Rated Power	W	4	8	12
Rated Current	A	0.2	0.4	0.6
Peak Current	A	0.6	1.2	1.8
Peak Torque	N.m	0.03	0.06	0.09
Rotor Inertia	kg.cm ²	0.01	0.02	0.03
Torque Constant	N.m/A	0.05	0.05	0.05
Torque Constant	V/krpm	4.5	4.5	4.5
Line-Line Resistance	Ω	2.1	3.2	3.9
Line-Line Inductance	mH	1.1	1.3	1.5
Length L1	mm	31.5	41.5	51.5
Weight	kg	0.2	0.3	0.4

Gearbox Electrical Specifications

Reduction stage		1	2	3
Transmission efficiency	%	90	81	73
Max radial load	N	10	10	10
Max axial load	N	6	6	6
Rated admissible torque	N.m	0.1	0.4	0.8
Reduction Ratio		3.71,5.18	14,19,27	57,71,100,139
Length L2	mm	21	27.2	33.4