

PLSP60 Low-Voltage Servo Motor

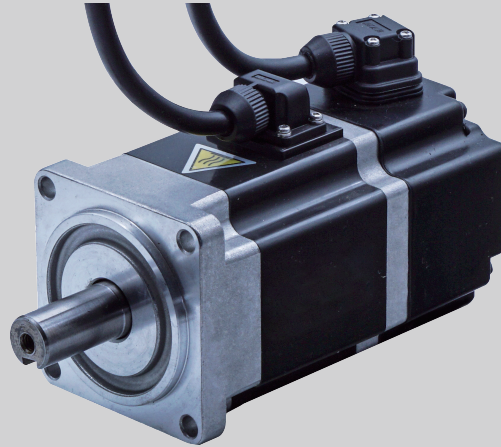

Specifications

Model	PLSP60-E0202030	PLSP60-E0402030	PLSP60-E0204030	PLSP60-E0404030	PLSP60-E0806030											
Rated Voltage(V)	24	48	24	48	80											
Rated Power(W)	200	200	400	400	600											
Rated Torque(N.m)	0.64	0.64	1.27	1.27	1.91											
Maximum Torque(N.m)	1.2	1.2	2.4	2.4	2.9											
Rated Speed(r/min)	3000	3000	3000	3000	3000											
Peak Speed (Rpm)	5000	5000	5000	5000	5000											
Rated Current (A)	16	6.5	25	12.8	13.6											
Rotor Inertia (Kg.m ² x10 ⁻⁴)	0.264	0.264	0.407	0.407	0.526											
Torque Coefficient(N.m/A)	0.04	0.1	0.05	0.1	0.1											
Electrical Time Constant (MS)	4.2	11	9.64	14	13.2											
Line Resistance (Ω)	0.09	0.33	0.056	0.15	0.68											
Line Inductance (MH)	0.32	3.7	0.54	2.1	9.0											
Line Back EMF Constant (V/krpm)	3.2	6	3.2	6.6	12.2											
Weight(kg)	1.3	1.3	1.8	1.8	2.1											
Number of Pole Pairs	4 (5 Pairs Of Poles Are Optional)															
Encoder Resolution (Ω)	2500CPR(Absolute encoder available)															
Insulation Class	Class F															
Protection Class	IP65 (IP67 Optional)															
Environment	Ambient Temperature:-20-50°C/Ambient Humidity~90%(No Frosting Condition)															
Winding Socket	Winding Wire	U			V			W			PE					
	Socket Number	1			2			3			4					
Encoder Socket (Absolute Type)	Signal Pin Definition	PE	5V	0V	SD+	SD-	VB+	VB-								
	Male Pin Number	1	2	3	4	5	6	7								
Encoder Socket (Incremental Type)	Signal Pin Definition	Shield	5V	0V	B+	Z-	U+	Z+	U-	A+	V+	W+	V-	A-	B-	W-
	Male Pin Number	1	2	3	4	5	6	7	8	9	10	11	12	13	14	15

Characteristic Curve

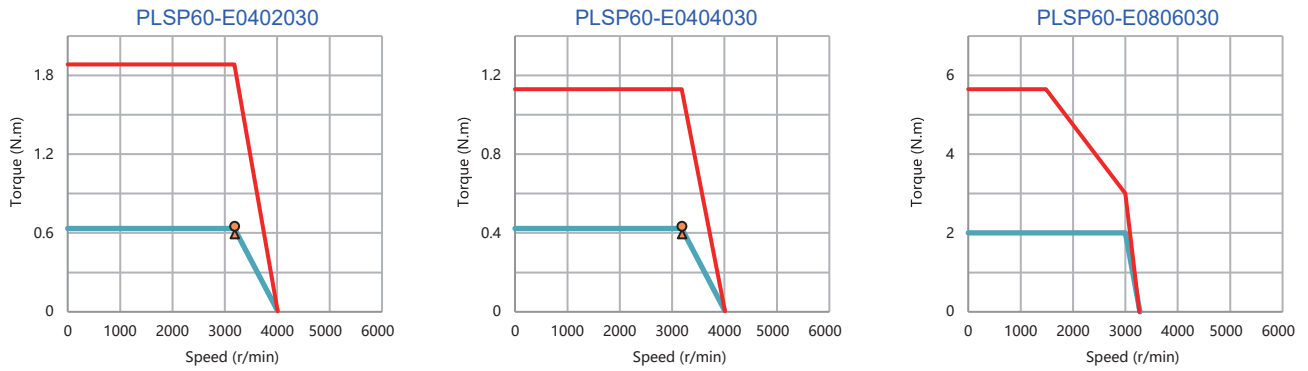

Dimensions

Motor Length	200W	400W	600W
L Without Brake (mm)	145	173	189
L With Brake (mm)	186	214	230

Without Brake

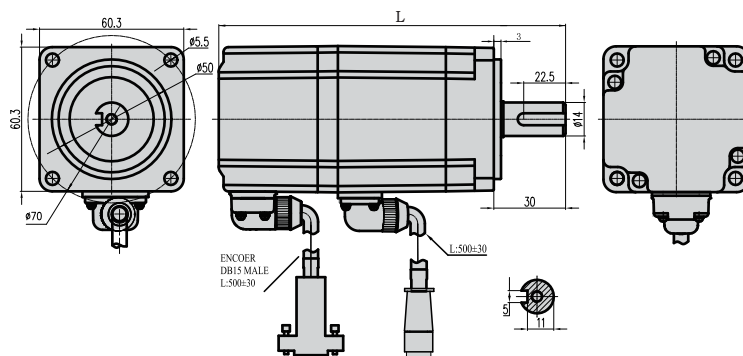

With Brake

