

# PBLD-S22035A

## High Performance Series



### Characteristics

- Input voltage: 110VAC~220 VAC
- Continuous output current: 3.5A
- Speed control and analog volume voltage: 0~5V
- Working temperature: 0~45°C
- Storage temperature: -20~+85°C
- Ambient humidity: <85%

### Dimension

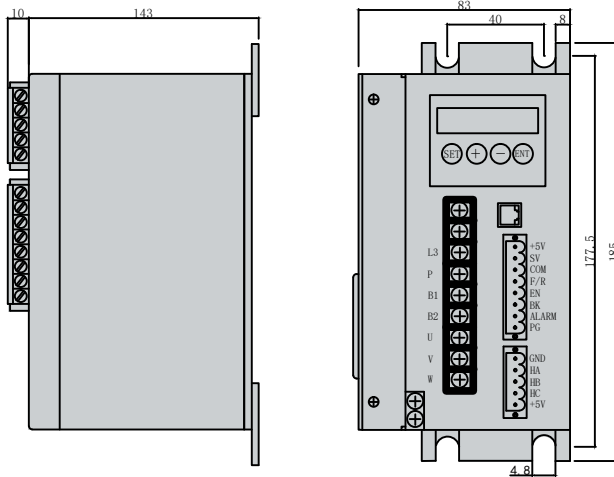

### Specification

- Closed loop control, constant torque output
- Input and output signal photoelectric isolation
- Support RS485 multi-axis communication control
- External analog, external pulse width input
- Start/stop control, forward/reverse control
- Electrical brake function, making the motor respond quickly
- Plugging protection, fast response, high control accuracy
- Load without deceleration, power compensation, high starting torque
- Overload multiplier greater than 2, torque always reaches maximum at low speed
- Over-voltage, under-voltage, over-current, over-temperature, Hall signal illegal and other fault alarm functions

### Connection Diagram

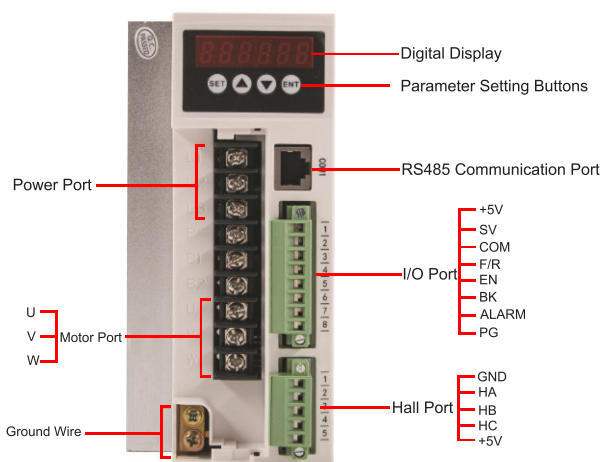

### Power input terminal

1	L1	AC input
2	L2	AC input
3	L3	Ground wire

### I/O control terminal

1	+5V	+5V power supply positive terminal
2	SV	Analog input
3	COM	Common terminal negative
4	F/R	Forward and reverse
5	EN	Start Stop
6	BK	Brake Control
7	ALARM	Alarm output
8	PG	Speed regulation voltage output

### Motor input terminal

1	U	Motor Phase A
2	V	Motor Phase B
3	W	Motor Phase C
4	PE	Ground wire

### Hall input terminal

1	GND	Negative power supply for Hall signal
2	HA	Hall signal A
3	HB	Hall signal B
4	HC	Hall signal C
5	+5V	Positive power supply for Hall signal