

PBLD-H220100A

Standard High-Voltage Series

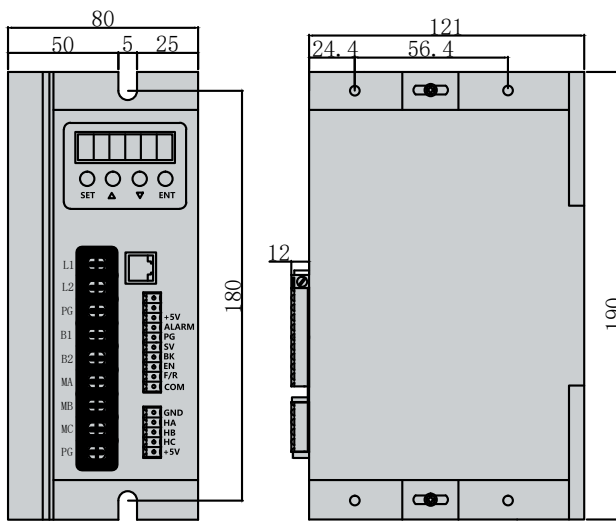

Dimension



Characteristics

- Input voltage: 110VAC~220VAC
- Continuous output current: 10A
- Speed control and analog volume voltage: 0~5V
- Working temperature: 0~45°C
- Storage temperature: -20~+85°C
- Ambient humidity: <85%

Specification

- Can be set with Hall or without Hall sensing drive, both are compatible
- The whole series adopts high quality devices, the circuit design is simple and clear, and the cost control is low
- Support RS485 multi-axis communication control
- External analog, external pulse width input
- Start/stop control, forward/reverse control
- Electrical brake function, making the motor respond quickly
- Plugging protection, fast response time, high control accuracy
- Load without deceleration, power compensation, high starting torque
- Overload multiplier greater than 2, torque always reaches maximum at low speed
- Over-voltage, under-voltage, over-current, over-temperature, Hall signal illegal and other fault alarm functions

Connection Diagram

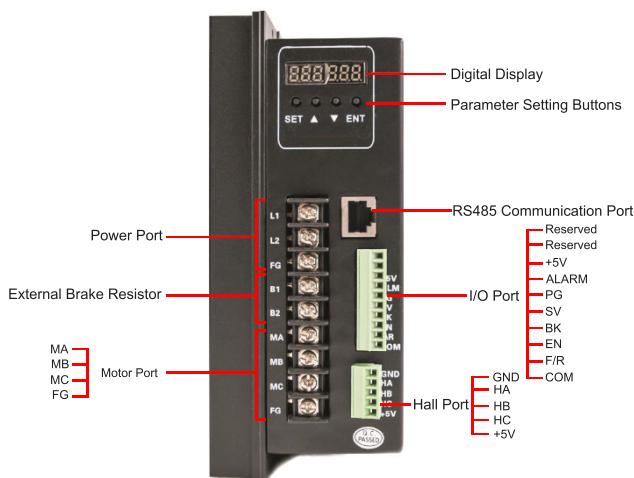

Power input terminal I/O control terminal

1	L1	AC input
2	L2	AC input
3	PE	Ground wire

1	Reserved	Customer Definition
2	Reserved	Customer Definition
3	+5V	Speed regulation voltage output

Motor input terminal

1	MA	Motor Phase A
2	MB	Motor Phase B
3	MC	Motor Phase C
4	FG	Ground wire

4	ALARM	Alarm output
5	PG	Speed pulse signal output
6	SV	Analog input
7	BK	Brake Control
8	EN	Start Stop

Hall input terminal

1	GND	Negative power supply for Hall signal
2	HA	Hall signal A
3	HB	Hall signal B
4	HC	Hall signal C
5	+5V	Positive power supply for Hall signal

9	F/R	Forward and reverse
10	COM	Public ports