

# PBLD-C22035A

## Compact Size High Performance Series



### Characteristics

- Input voltage: 110VAC~220 VAC
- Continuous output current: 3.5A
- Speed control and analog volume voltage: 0~5V
- Working temperature: 0~45°C
- Storage temperature: -20~+85°C
- Ambient humidity: <85%

### Dimension

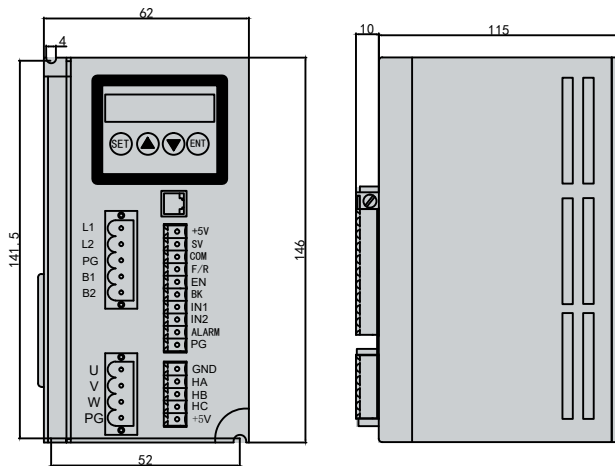

### Specification

- Small size, power up to 400W, exquisite design
- DSP chip + IGBT intelligent module isolated drive + patented PID + PWM control
- Support RS485 multi-axis communication control
- Segmented speed control, 2 input ports, 4 different speed states can be set
- PC-based debugging software can be used to set and modify drive software parameters
- Perfect protection functions such as over-voltage, under-voltage, over-current, over-speed, wrong phase, short-circuit, etc.

### Connection Diagram

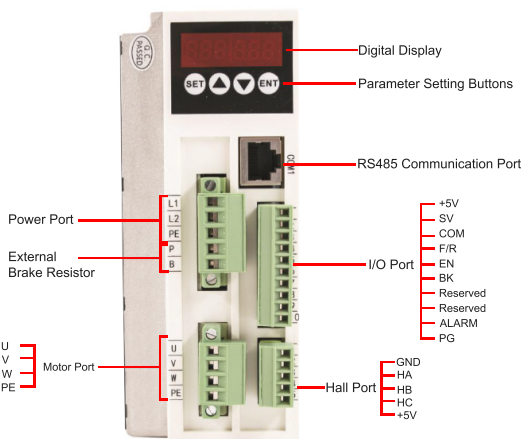

### Power input terminal

1	L1	AC input
2	L2	AC input
3	PE	Ground wire

### I/O control terminal

1	+5V	+5V power supply positive terminal
2	SV	Analog input
3	COM	Common terminal negative
4	F/R	Forward and reverse
5	EN	Start Stop
6	BK	Brake Control
7	Reserved	Customer Definition
8	Reserved	Customer Definition
9	ALARM	Alarm output
10	PG	Speed pulse signal output

### Motor input terminal

1	U	Motor Phase A
2	V	Motor Phase B
3	W	Motor Phase C
4	PE	Ground wire

### Hall input terminal

1	GND	Negative power supply for Hall signal
2	HA	Hall signal A
3	HB	Hall signal B
4	HC	Hall signal C
5	+5V	Positive power supply for Hall signal