

# PBLR42GES Series

## Planetary Gearbox BLDC Motor

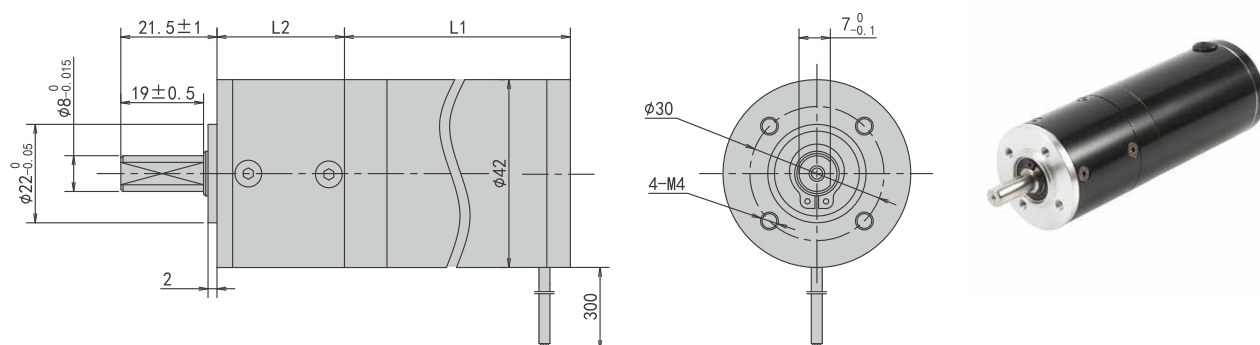

### Motor Specifications

Motor Model	Unit	PBLR42GES242830	PBLR42GES245630	PBLR42GES248430
Number of Phase		3		
Number of Poles		8		
Rated Voltage	VDC	24		
Rated Speed	Rpm	3000		
Rated Torque	N.m	0.09	0.18	0.27
Rated Power	W	28	56	84
Rated Current	A	1.7	3.4	5.4
Peak Current	A	5.1	10.2	16
Peak Torque	N.m	0.27	0.54	0.81
Rotor Inertia	kg.cm <sup>2</sup>	0.25	0.35	0.45
Torque Constant	N.m/A	0.05	0.05	0.05
Torque Constant	V/krpm	5.23	5.23	5.23
Line-Line Resistance	Ω	6	4	3
Line-Line Inductance	mH	4	3	2
Length L1	mm	52	72	92
Weight	kg	0.28	0.48	0.68

### Gearbox Electrical Specifications

Reduction stage		1	2
Transmission efficiency	%	95	90
Max radial load	N	200	200
Max axial load	N	100	100
Rated admissible torque	N.m	6	12
Reduction Ratio		5,10	20,25,40,45,50,100
Length L2	mm	28.5	38