

PBLS86GES Series

Planetary Gearbox BLDC Motor

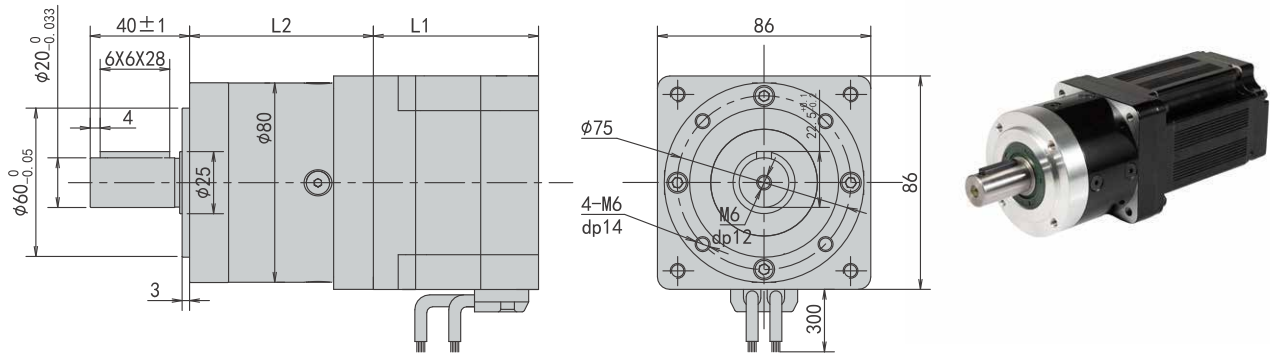

Electrical Specifications

Motor Model	Unit	PBLS86GES482230	PBLS86GES483130
Number of Phase		3	
Number of Poles		8	
Rated Voltage	VDC	48	
Rated Speed	Rpm	3000	
Rated Torque	N.m	0.7	1.0
Rated Power	W	220	310
Rated Current	A	5.8	8.6
Peak Current	A	17.4	25.8
Peak Torque	N.m	2.1	3.0
Rotor Inertia	kg.cm ²	1.6	1.9
Torque Constant	N.m/A	0.12	0.11
Torque Constant	V/krpm	11	10.5
Line-Line Resistance	Ω	0.6	0.5
Line-Line Inductance	mH	0.5	0.4
Length L1	mm	66.5	80.5
Weight	kg	1.8	2.2

Gearbox Electrical Specifications

Reduction stage		1	2
Transmission efficiency	%	95	90
Max radial load	N	1000	1000
Max axial load	N	500	500
Rated admissible torque	N.m	50	80
Reduction Ratio		5,10	15,20,25,30,40,50
Length L2	mm	74	93