

PBL57GES Series

Planetary Gearbox BLDC Motor

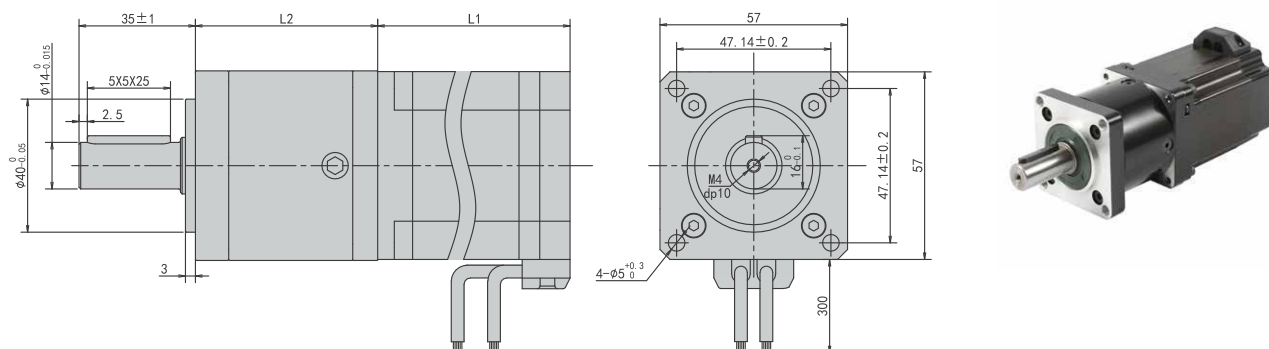

Motor Specifications

Motor Model	Unit	PBL57GES486030	PBL57GES481230	PBL57GES481830
Number of Phase		3		
Number of Poles		8		
Rated Voltage	VDC	48		
Rated Speed	Rpm	3000		
Rated Torque	N.m	0.2	0.4	0.6
Rated Power	W	63	125	188
Rated Current	A	1.6	3.3	5.0
Peak Current	A	4.8	9.9	15.0
Peak Torque	N.m	0.6	1.2	1.8
Rotor Inertia	kg.cm ²	0.25	0.35	0.45
Torque Constant	N.m/A	0.125	0.121	0.12
Torque Constant	V/krpm	13.08	12.71	12.56
Line-Line Resistance	Ω	1.11	0.93	0.52
Line-Line Inductance	mH	0.91	0.65	0.43
Length L1	mm	58	78	98
Weight	kg	1.0	1.4	1.8

Gearbox Electrical Specifications

Reduction stage		1	2
Transmission efficiency	%	95	90
Max radial load	N	580	580
Max axial load	N	340	340
Rated admissible torque	N.m	25	40
Reduction Ratio		5,10	15,20,25,30,40,50
Length L2	mm	55	71