

PHH28Y Series

● Key Features

- Small Size
- Smooth Movement
- Low Inertia



| | |
|-----------------------|---------------------------------------|
| Step Angle | 1.8° |
| Step Angle Accuracy | ±5% (full step, no load) |
| Resistance Accuracy | ±10% |
| Inductance Accuracy | ±20% |
| Temperature Rise | 80 °C Max.(rated current, 2 phase on) |
| Ambient Temperature | -20 °C ~ +50 °C |
| Insulation Resistance | 100 MΩ Min., 500VDC |
| Dielectric Strength | 500 VAC for one minute |
| Shaft Radial Play | 0.02 Max. (450 g-load) |
| Shaft Axial Play | 0.08 Max. (450 g-load) |

● Specifications

- Bi-polar

| Series & Length | Model Number | Holding Torque | | Rated Current | Resistance per phase | Inductance per phase | Detent Torque | | Rotor Inertia | |
|------------------|--------------|----------------|-------|---------------|----------------------|----------------------|---------------|-------|-------------------|--------------------|
| | | N.cm | oz-in | A | ohm | mH | N.cm | oz-in | g.cm ² | oz-in ² |
| PHH28Y28 28mm | PHH28Y28-401 | 4.5 | 6.3 | 0.6 | 4.2 | 2.2 | 0.3 | 0.42 | 6 | 0.033 |
| PHH28Y33 33mm | PHH28Y33-401 | 6.0 | 8.4 | 0.6 | 5.5 | 3.2 | 0.4 | 0.56 | 8 | 0.044 |
| PHH28Y41 41mm | PHH28Y41-401 | 8.0 | 11.2 | 0.6 | 7.0 | 6.0 | 0.5 | 0.7 | 11 | 0.061 |
| PHH28Y50 50mm | PHH28Y50-401 | 10 | 14 | 0.6 | 9.0 | 7.2 | 0.8 | 1.12 | 13 | 0.072 |

● Mechanical Dimension

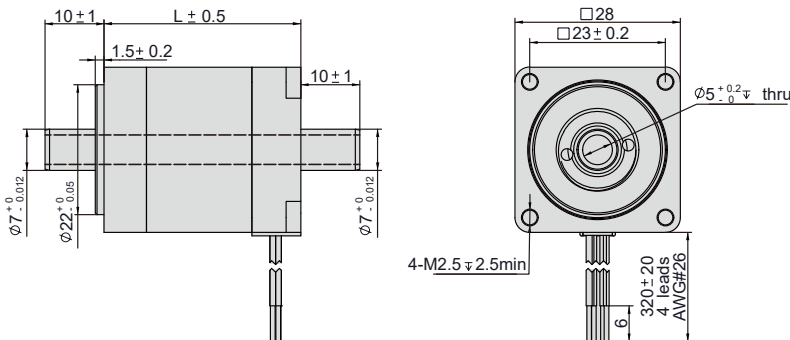

| Series | L | Mass |
|----------|-----------|------------|
| | mm (in.) | g (lb.) |
| PHH28Y28 | 28 (1.10) | 95 (0.19) |
| PHH28Y33 | 33 (1.29) | 110 (0.24) |
| PHH28Y41 | 41 (1.61) | 140 (0.30) |
| PHH28Y50 | 50 (1.96) | 180 (0.39) |

2Phase Hybrid Stepper Motor

3Phase Hybrid Stepper Motor

5Phase Hybrid Stepper Motor

Hybrid Stepper Gear Motor

Lead Screw Linear Actuator

Ball Screw Linear Actuator

IP65 Stepper Motor

Hollow Shaft Stepper Motor

Stepper Motor With Brake

Pancake Stepper Motor

PM Stepper Motor

Can-Stack Stepper Linear Actuator

PM Stepper Gear Motor

Stepper Motor Drive