

PHG57S Series

● Key Features

- High Torque
- High Precision
- Long Lifetime



● Stepper Motor Electrical Specifications

Series Model	Rated Current (A)	Phase Resistance (Ω)	Phase Inductance (mH)	Lead Wire (No.)	Holding Torque (N.m)	Motor Length L (mm)	Rotor Inertia (g.cm ²)	Motor Weight (g)	Step Angle (°)
PHG57S56-404	4.2	0.35	1.2	4	1.1	56	280	0.68	1.8
PHG57S76-404		0.55	1.8		1.8	76	440	1.05	
PHG57S100-404		0.75	3.0		2.5	100	680	1.25	

● Planetary Gearbox Technical Data

Gear Ratio		Length L1 (mm)	Efficiency	Rated Torque (N.m)	Permissible Torque (Max) (N.m)	Noise (dB)	Backlash min. at No-load	Weight (g)
1 Stage	5	55	95%	25	40	@1m ≤60dB	≤15arcmin	600-800
	10							
2 Stage	15	71	90%	40	60		≤25arcmin	800-960
	20							
	25							
	30							
	40							
50								

● Dimensions(Unit:mm)

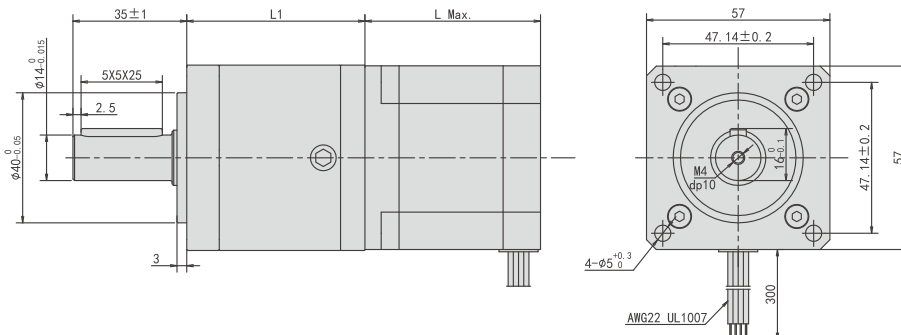

2Phase Hybrid Stepper Motor

3Phase Hybrid Stepper Motor

5Phase Hybrid Stepper Motor

Hybrid Stepper Gear Motor

Lead Screw Linear Actuator

Ball Screw Linear Actuator

IP65 Stepper Motor

Hollow Shaft Stepper Motor

Stepper Motor With Brake

Pancake Stepper Motor

PM Stepper Motor

Can-Stack Stepper Linear Actuator

PM Stepper Gear Motor

Stepper Motor Drive