

PHB60F Series

● **Key Features**

- Small Size
- Smooth Movement
- Low Noise



Step Angle	0.72°
Step Angle Accuracy	±5% (full step, no load)
Resistance Accuracy	±10%
Inductance Accuracy	±20%
Temperature Rise	80 °C Max.(rated current,5 phase on)
Ambient Temperature	-20 °C ~ +50 °C
Insulation Resistance	100 MΩ Min., 500VDC
Dielectric Strength	500 VAC for one minute
Shaft Radial Play	0.02 Max. (450 g-load)
Shaft Axial Play	0.08 Max. (450 g-load)

● **Specifications**

- 5 Wires

Series & Length	Model Number	Holding Torque		Rated Current	Resistance per phase	Inductance per phase	Detent Torque		Rotor Inertia	
		N.cm	oz-in	A	ohm	mH	N.cm	oz-in	g.cm ²	oz-in ²
PHB60F45 45mm	PHB60F45-508	55	77	0.75	2.6	4.6	3.0	4.2	250	1.375
	PHB60F45-515	55	77	1.5	0.65	0.9	3.0	4.2	250	1.375
PHB60F54 54mm	PHB60F54-508	80	112	0.75	3.3	8.2	3.5	4.9	280	1.540
	PHB60F54-515	80	112	1.5	0.77	1.6	3.5	4.9	280	1.540
PHB60F64 64mm	PHB60F64-508	100	140	0.75	4	9.2	5.0	7	380	2.090
	PHB60F64-515	100	140	1.5	0.8	1.8	5.0	7	380	2.090
PHB60F76 76mm	PHB60F76-508	130	182	0.75	5	13.5	6.5	9.1	440	2.420
	PHB60F76-515	130	182	1.5	0.98	2.6	6.5	9.1	440	2.420
PHBB60F90 90mm	PHB60F90-508	160	224	0.75	5.8	19.5	8.0	11.2	580	3.190
	PHB60F90-515	160	224	1.5	1.2	3.8	8.0	11.2	580	3.190

● **Mechanical Dimension**

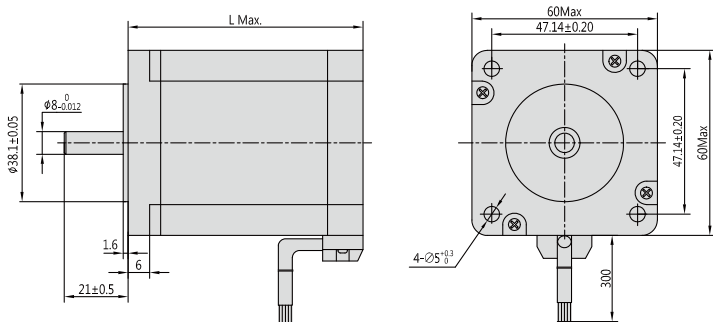

Series	L	Mass
	mm (in.)	g (lb.)
PHB60F45	45 (1.77)	600 (2.13)
PHB60F54	54 (2.13)	780 (1.72)
PHB60F64	64 (2.52)	920 (2.02)
PHB60F76	76 (2.99)	1250 (2.76)
PHB60F90	90 (3.54)	1600 (3.53)