



RV25 Diaphragm Pump (Stainless steel center body)

1. Overview

The RV series air-operated diaphragm pump of our company is a latest model of fluid transportation equipment, which is currently one of the most innovative pumps in china. Using compressed air as the power source, it can pump various fluids drastically, whether corrosive, volatile, flammable, poisonous liquid or fluids with particles and high viscosity.

Our diaphragm pumps have totally six specifications. The sizes for import/export are 1/4", 1/2", 3/4", 1", 1.5", 2", 3" and 4". The components which contact with the fluids are usually made of aluminum alloy, nodular cast iron, polypropylene, stainless steel. Depend on the varied applications, and the materials of diaphragm can be styrene rubber, neoprene, polythene, polyether rubber, fluorine rubber, Teflon and PVDF, so that it can meet the requirements of different fluid mediums.

INSTALLATION

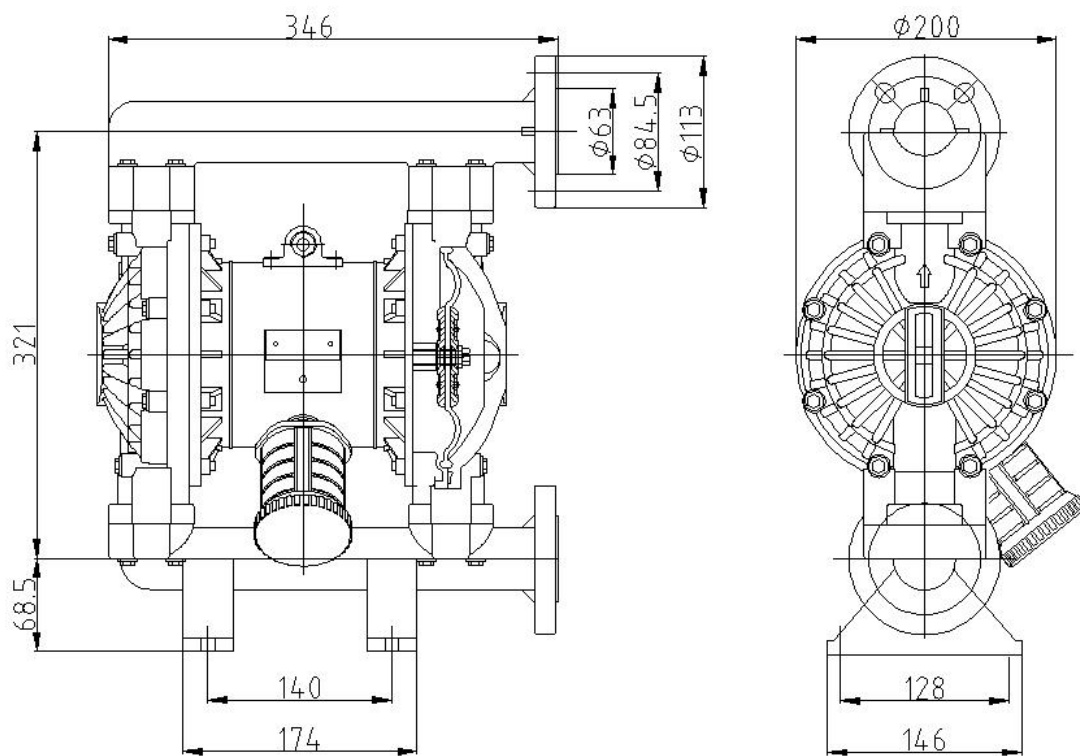

RV25 PVDF (FLANGE)

Technical Curve

