



RV 40 Sanitary Diaphragm Pump

I. Product Overview of RV Sanitary Grade Pneumatic Diaphragm Pump

The RV Hygienic Pneumatic Diaphragm Pump was developed for hygienic grades and is used primarily in the food and pharmaceutical industries. This pump is ideal for applications where the surface of the device is required to achieve an electro polished 32Ra. The clamp is designed with easy removal. The pump body is made of food grade stainless steel, the diaphragm material is food grade Teflon or EPDM rubber, and the fluid contact area is in compliance with FDA standards.

2.Features and Benefits

- All fluid contact materials are FDA-compliant
- FDA Plus pumps have a 304/316 stainless steel center section
- Seats, balls and diaphragms are available in a wide range of food grade elastomers, and long service life
- Dual cup air valve – one of the most reliable air valves in the market.
- Quick release clamp design, for flexible disassemble and assemble

3. RV40 Sanitary Grade (FDA) Pneumatic Diaphragm Pump

A、 Dimensional Drawing

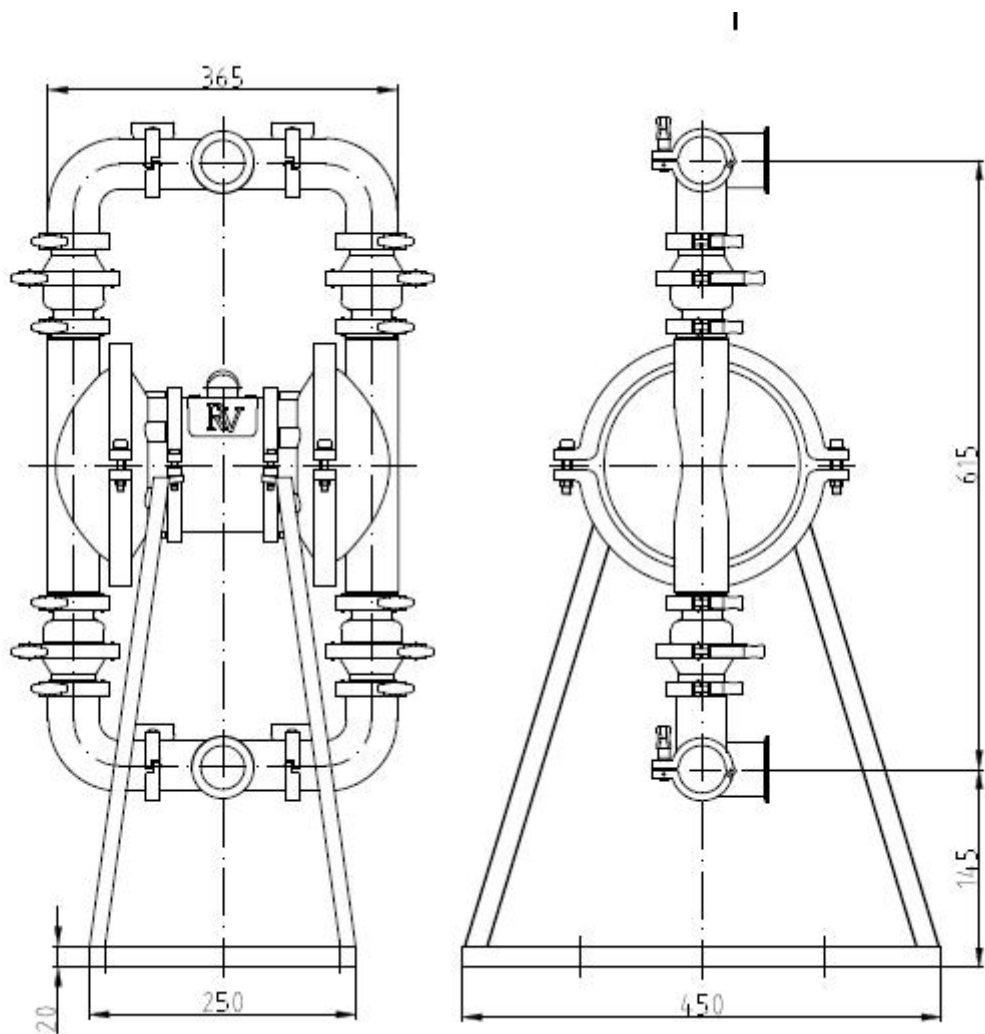

B、 Technical Curve

40曲线图

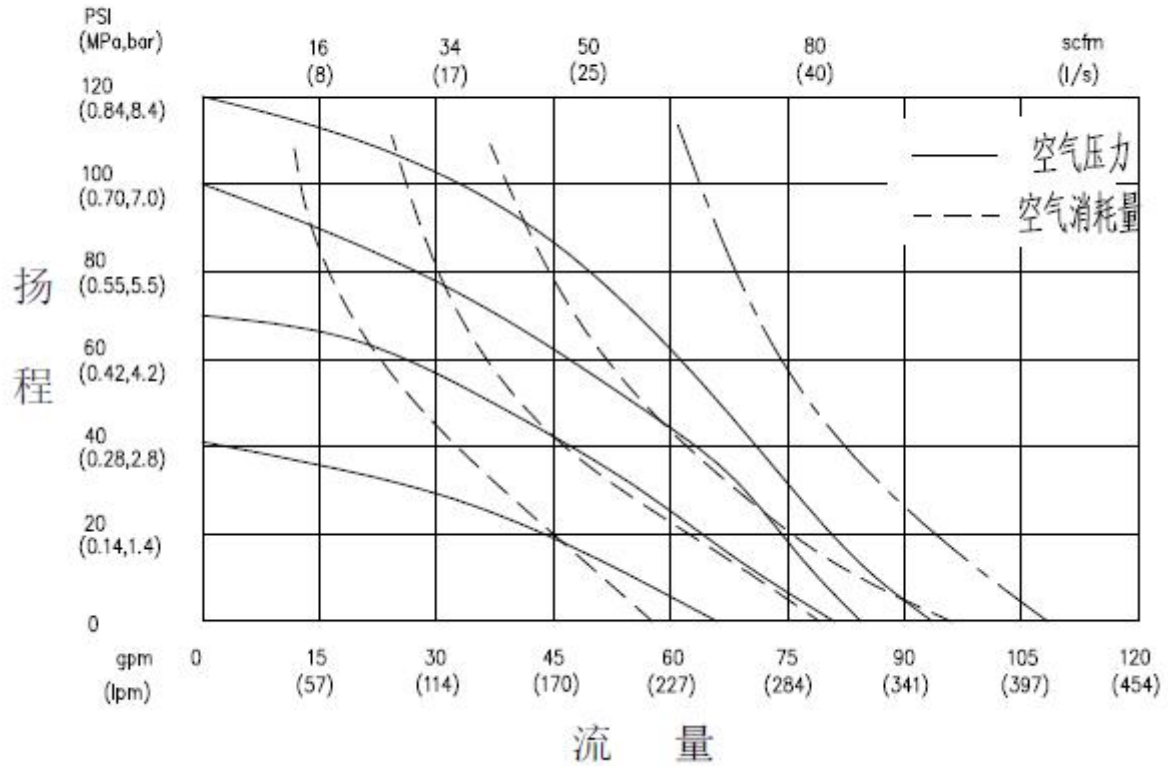

C. Technical Parameters

Max. Working Pressure: 0.5 Mpa

Max. Flow Rate: 350 lpm

Max. Reciprocating Speed: 170 cpm

Max. Suction Height: 5 m

Max. Permitted Grain: 3.0 mm

Max. Air Consumption: 17 L/s

Air Inlet Size: 1/2 in

Air Outlet Size: 3/4 in

Fluid Inlet Size: 1-1/2 in

Fluid Outlet Size: 1-1/2 in

Connection: Clamp

Pump Body: 304 Stainless Steel